

ETH Course 402-0248-00L: Electronics for Physicists II (Digital)

- **1: Setup uC tools, introduction**
- **2: Solder SMD Arduino Nano board**
- **3: Build application around ATmega328P**
- **4: Design your own PCB schematic**
- **5: Place and route your PCB**
- **6: Start logic design with FPGAs**

The ATmega168P / 328P

- AT = Atmel: Big microcontroller company
- mega: microcontroller family
- 16: 16KB Flash memory / 32: 32KB Flash
- 8: 8-bit architecture
- P: PicoPower Technology. Optional. For low power battery-based applications.

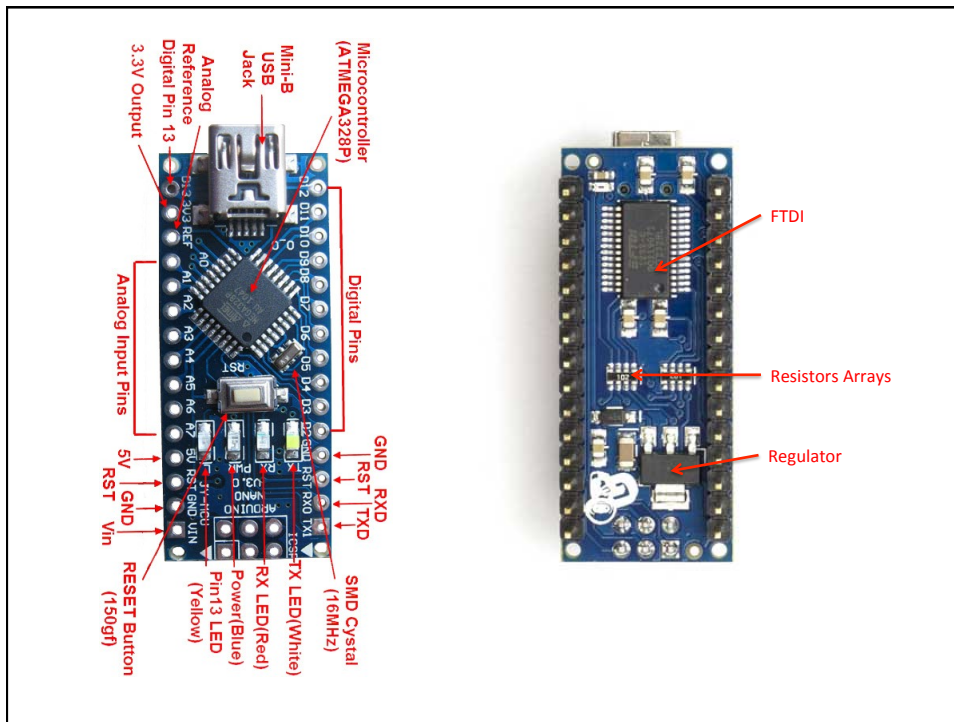

ATmega16/328P capabilities (Ex. 3)

- **System Functions**
 - Power and Clock Manager
 - Low Freq Internal Oscillator
 - Watchdog Timer
 - Real-Time Clock Timer
- **Interrupt Controller**
 - Fixed priority. One level of interruption. Interruptions with flag (can remember) or without. Global Interrupt Enable (I-bit) is disabled during an interrupt service.
- **NO Universal Serial Bus (USB)**
 - This micro hasn't USB. The nano board provide an USB-USART interface from FTDI company.
- **One 16-bit Timer/ Counter (TC) with Auto-Reload and PWM**
- **Two 8-bit Timer / Counter (TC) with AR and PWM**
- **One 8-channel 10-bit Analog-To-Digital Converter (ADC), 76.9ks/s**
- **SPI, USART, I2C**

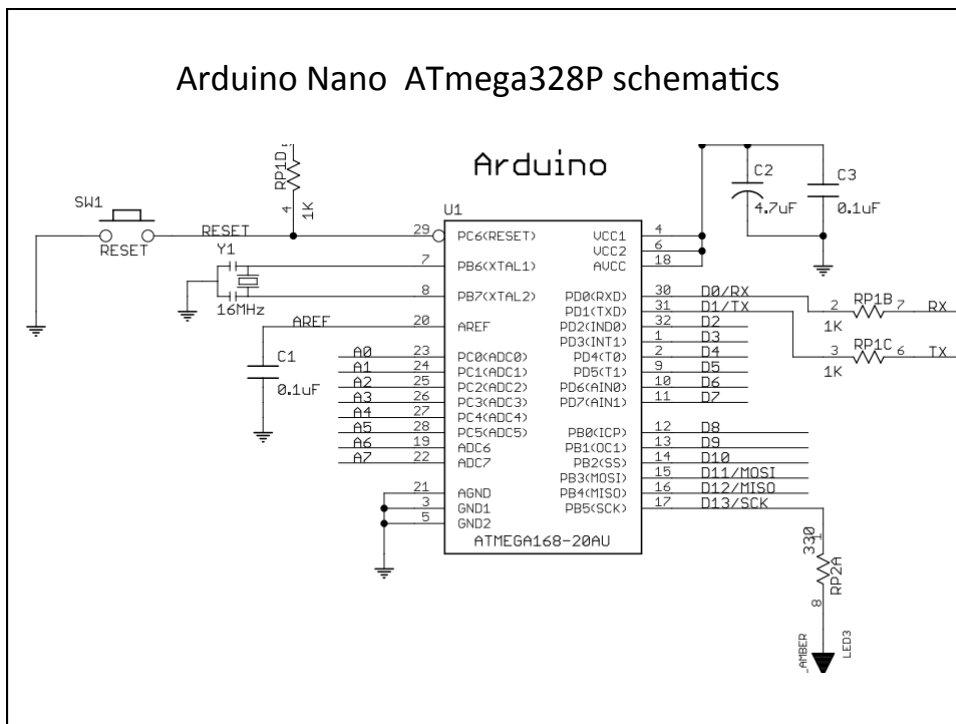
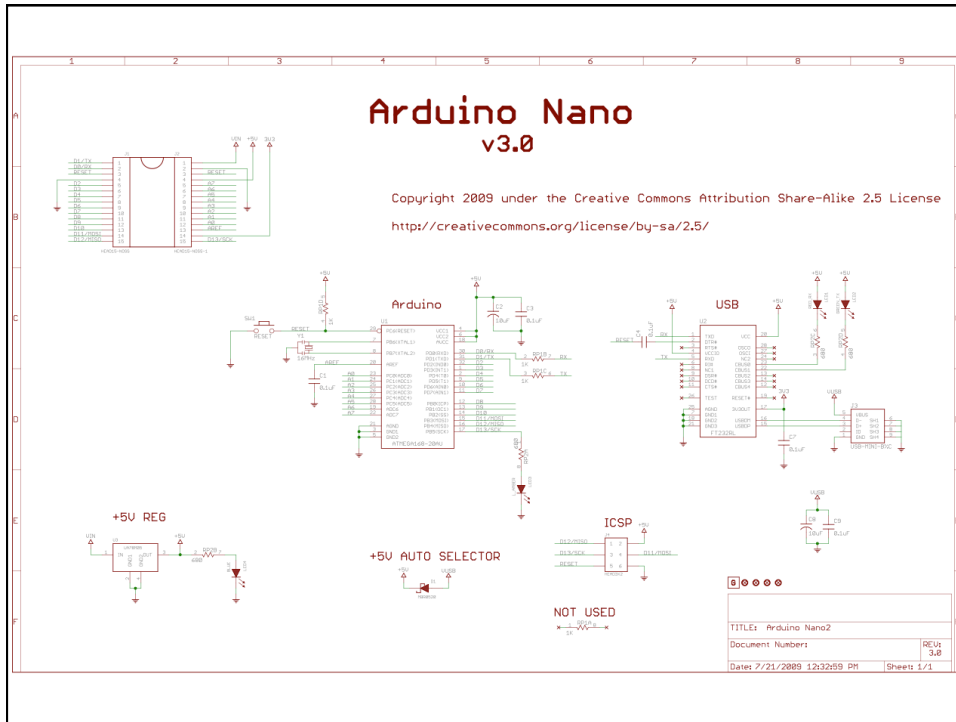

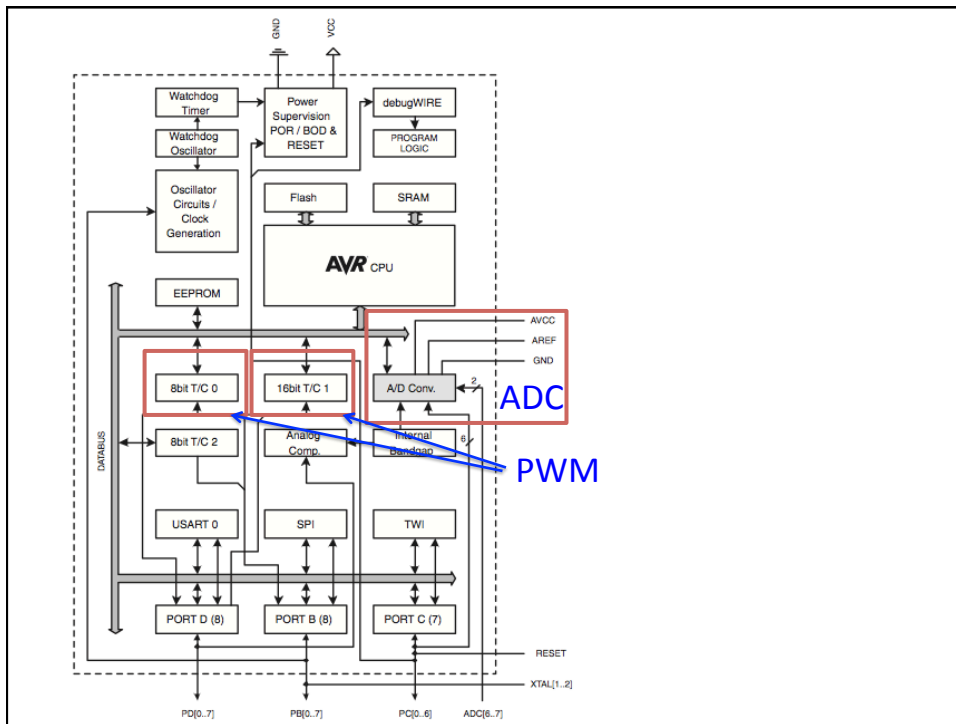

Exercise 3: "Sound volume robot"

- measures sound volume and moves arm to indicate loudness
- microphone -> preamp -> ADC -> uC -> PWM output

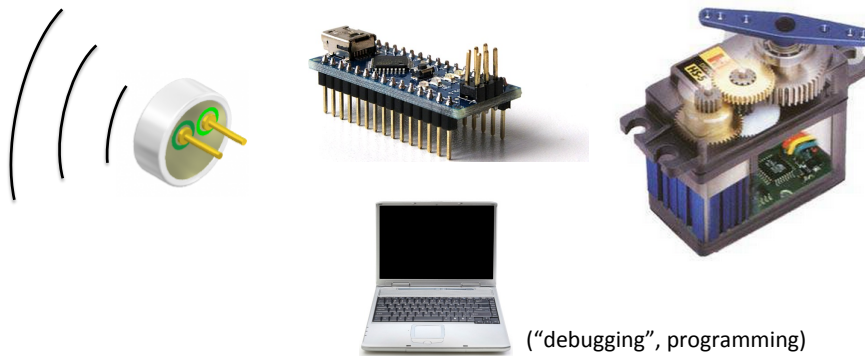

“RC” servos (Radio-Control Servo-Motors)



- Position controlled – Servo has internal position measurement and controller
- Rotation angle 120 degrees
- Pulse width from 1-2ms sets desired position
- Pulses must be sent at frequency 50-200Hz
- Pulse height >2V

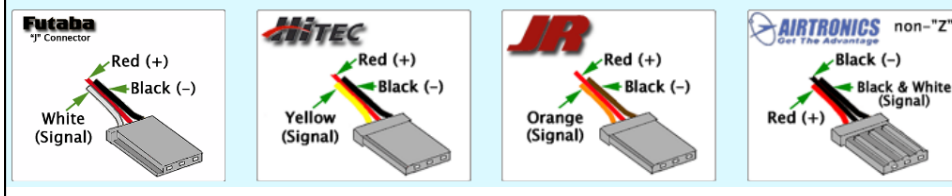

Electret Microphone

- Cheap (< 1\$)
- Electret material, no polarization voltage is required
- Low-noise JFET buffer
- Metal foil is connected to source of the JFET through metal capsule

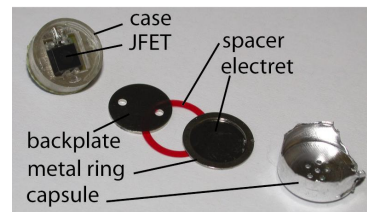
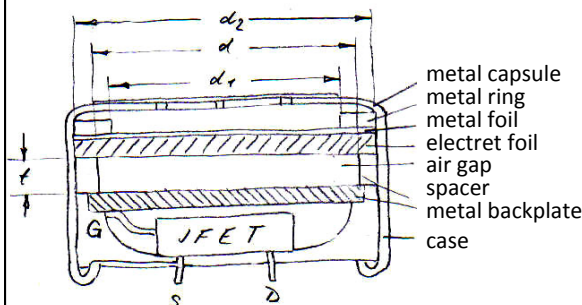
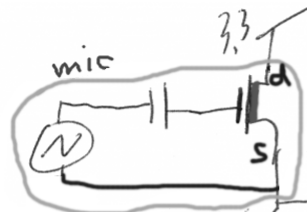

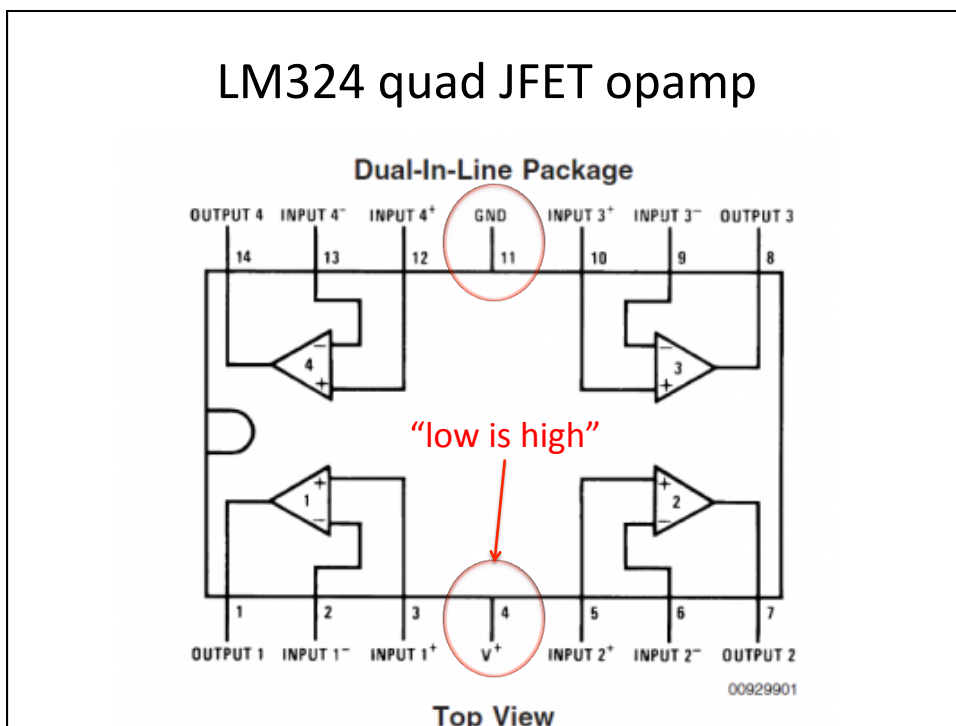
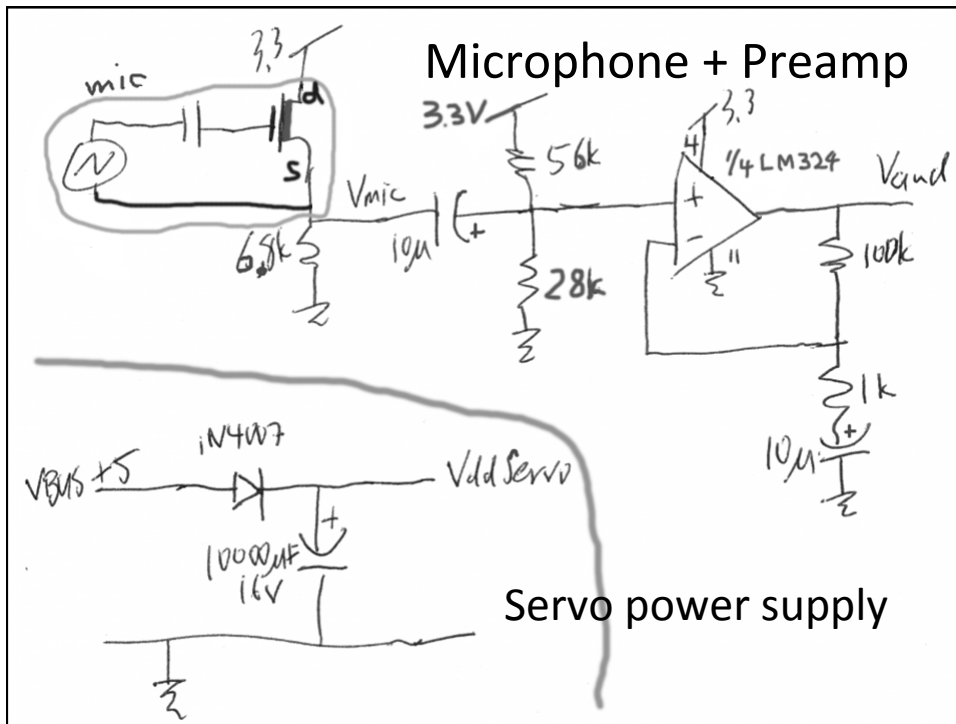

ATmega328P Analog to Digital converter

- 10-bit Successive approximation register (SAR) type
- 8 multiplexed single-ended input channels
- Internal Temp sensor
- Max combined sample rate 79.6ks/s
- Interrupt on End of Conversion.
- Triggered by:
 - External Interrupt Request 0
 - Timer 0
 - Timer 1
 - Analog Comparator

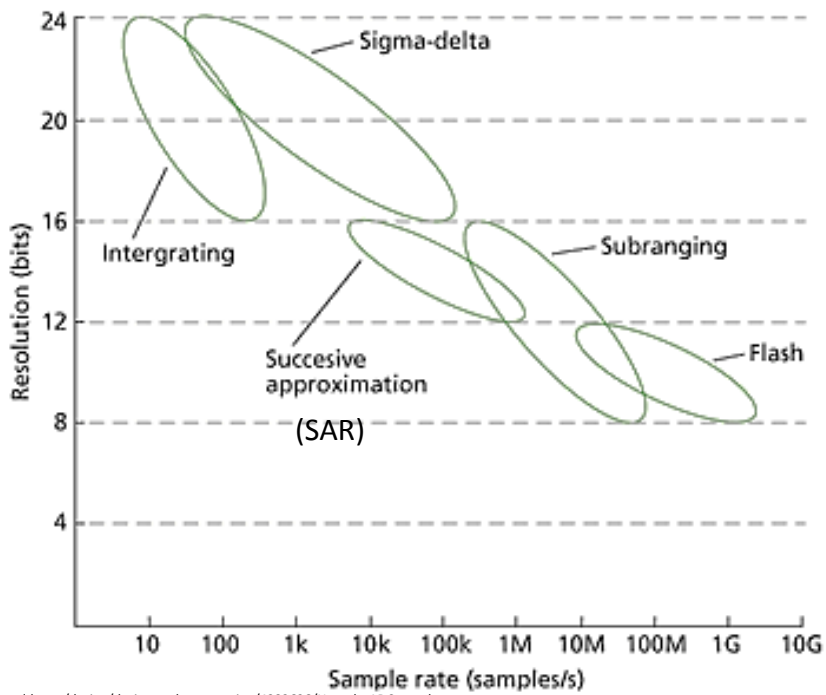
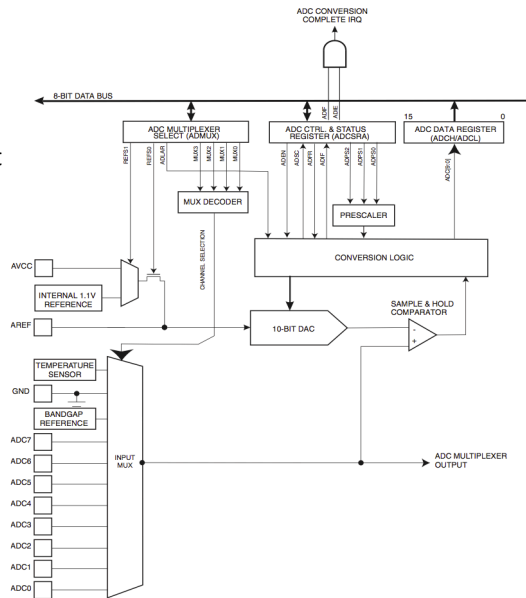

<http://tmworld.com/design/design-and-prototyping/4383626/How-do-ADCs-work->

